

RECOMMENDED PC BOARD HOLE PATTERN
 PC BOARD THICKNESS 1.57[.062]

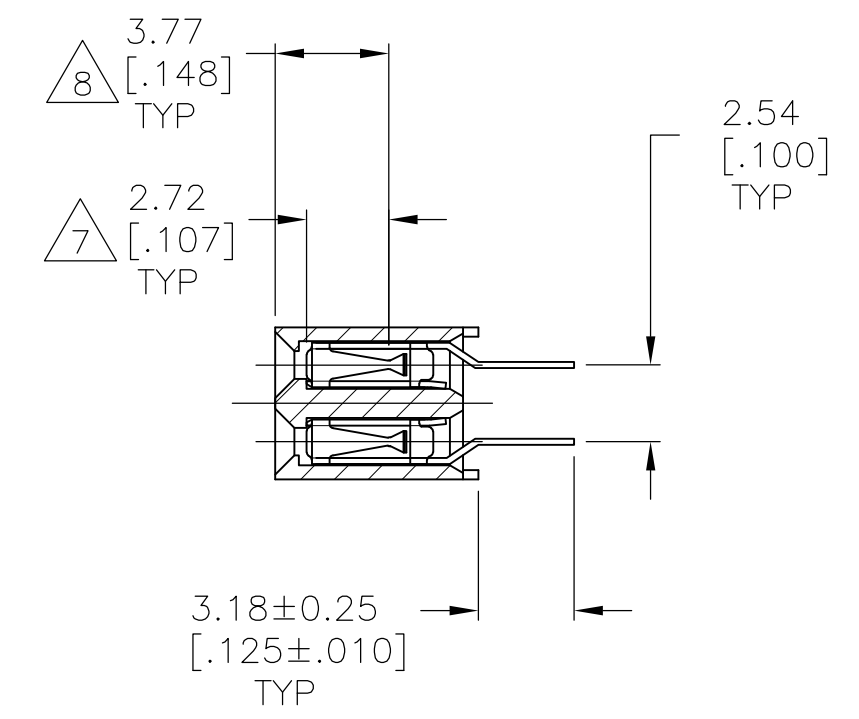
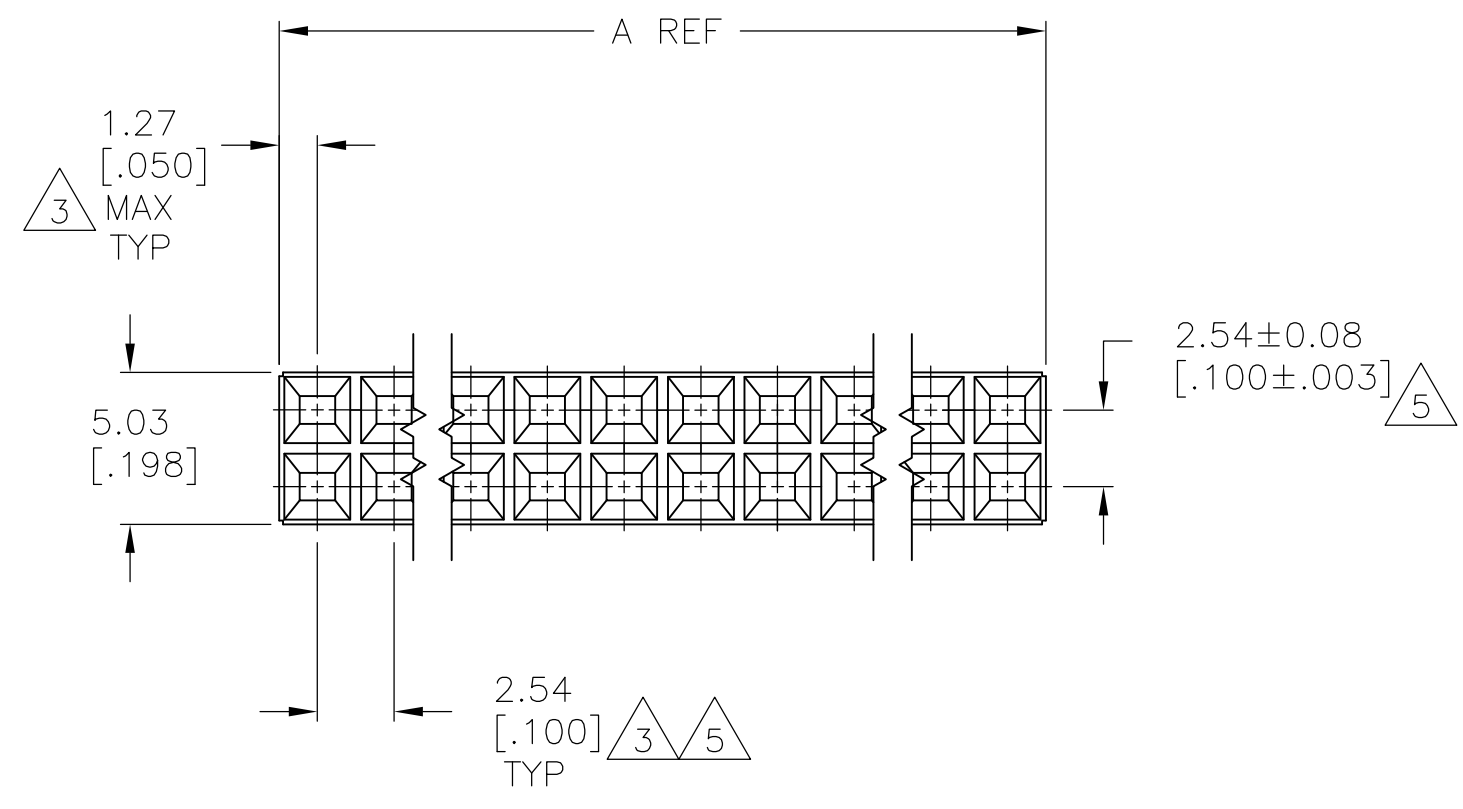

- 1 HOUSING: FLAME RETARDANT, GLASS FILLED, THERMOPLASTIC, COLOR: BLACK. CONTACT: PHOSPHOR BRONZE
- 2 CONTACT: AREA, 2.54-5.08µm[.000100-.000200] BRIGHT TIN-LEAD OVER 1.27µm[.000050] MIN NICKEL
- 3 THESE DIMENSIONS PERTAIN TO CAVITY CENTERLINES ONLY - NOT TO CONTACT LOCATIONS
- 4 PART NUMBER AND DATE CODE ARE MARKED IN APPROXIMATE LOCATION SHOWN.
- 5 TOLERANCE IS NON-CUMULATIVE.
- 6 2 POSITION DATE CODE IS MARKED OPPOSITE SIDE OF TE LOGO.
- 7 POINT-OF-MEASUREMENT DIMENSION FOR PLATING THICKNESS (INSIDE CONTACT BEAM).
- 8 POINT-OF-CONTACT DIMENSION.
- 9 CONTACT: AREA, 2.54-5.08µm[.000100-.000200] MATTE TIN OVER 1.27µm[.000050] MIN NICKEL
- 10 TE TRADEMARK AND CSA LOGO ARE MOLDED INTO HOUSING, THIS LOCATION.
- 11 NO PART NUMBER MARKING REQUIRED FOR THIS PART.
- 12 ROHS 2002/95/EC COMPLIANT.

SUPERSEDED BY 6-535585-0

9	35.56[1.400]	38.10[1.500]	30	4-535585-1
	96.52[3.800]	99.06[3.900]	78	4-535585-0
	93.98[3.700]	96.52[3.800]	76	3-535585-9
	91.44[3.600]	93.98[3.700]	74	3-535585-8
	88.90[3.500]	91.44[3.600]	72	3-535585-7
	86.36[3.400]	88.90[3.500]	70	3-535585-6
	83.82[3.300]	86.36[3.400]	68	3-535585-5
	81.28[3.200]	83.82[3.300]	66	3-535585-4
	78.74[3.100]	81.28[3.200]	64	3-535585-3
	76.20[3.000]	78.74[3.100]	62	3-535585-2
	71.12[2.800]	73.66[2.900]	58	3-535585-1
	68.58[2.700]	71.12[2.800]	56	3-535585-0
	66.04[2.600]	68.58[2.700]	54	2-535585-9
	63.50[2.500]	66.04[2.600]	52	2-535585-8
	58.42[2.300]	60.96[2.400]	48	2-535585-7
	55.88[2.200]	58.42[2.300]	46	2-535585-6
	53.34[2.100]	55.88[2.200]	44	2-535585-5
	50.80[2.000]	53.34[2.100]	42	2-535585-4
	99.06[3.900]	101.60[4.000]	80	2-535585-3
	73.66[2.900]	76.20[3.000]	60	2-535585-2
	60.96[2.400]	63.50[2.500]	50	2-535585-1
	48.26[1.900]	50.80[2.000]	40	2-535585-0
	45.72[1.800]	48.26[1.900]	38	1-535585-9
	43.18[1.700]	45.72[1.800]	36	1-535585-8
	40.64[1.600]	43.18[1.700]	34	1-535585-7
	38.10[1.500]	40.64[1.600]	32	1-535585-6
	35.56[1.400]	38.10[1.500]	30	1-535585-5
	33.02[1.300]	35.56[1.400]	28	1-535585-4
	30.48[1.200]	33.02[1.300]	26	1-535585-3
	27.94[1.100]	30.48[1.200]	24	1-535585-2
	25.40[1.000]	27.94[1.100]	22	1-535585-1
	22.86[.900]	25.40[1.000]	20	1-535585-0
	20.32[.800]	22.86[.900]	18	535585-9
	17.78[.700]	20.32[.800]	16	535585-8
	15.24[.600]	17.78[.700]	14	535585-7
	7.62[.300]	10.16[.400]	8	535585-6
	5.08[.200]	7.62[.300]	6	535585-5
	2.54[.100]	5.08[.200]	4	535585-4
	-	2.54[.100]	2	535585-3
	12.70[.500]	15.24[.600]	12	535585-2
	10.16[.400]	12.70[.500]	10	535585-1

	96.52[3.800]	99.06[3.900]	78	9-535585-0
	93.98[3.700]	96.52[3.800]	76	8-535585-9
	91.44[3.600]	93.98[3.700]	74	8-535585-8
	88.90[3.500]	91.44[3.600]	72	8-535585-7
	86.36[3.400]	88.90[3.500]	70	8-535585-6
	83.82[3.300]	86.36[3.400]	68	8-535585-5
	81.28[3.200]	83.82[3.300]	66	8-535585-4
	78.74[3.100]	81.28[3.200]	64	8-535585-3
	76.20[3.000]	78.74[3.100]	62	8-535585-2
	71.12[2.800]	73.66[2.900]	58	8-535585-1
	68.58[2.700]	71.12[2.800]	56	8-535585-0
	66.04[2.600]	68.58[2.700]	54	7-535585-9
	63.50[2.500]	66.04[2.600]	52	7-535585-8
	58.42[2.300]	60.96[2.400]	48	7-535585-7
	55.88[2.200]	58.42[2.300]	46	7-535585-6
	53.34[2.100]	55.88[2.200]	44	7-535585-5
	50.80[2.000]	53.34[2.100]	42	7-535585-4
	99.06[3.900]	101.60[4.000]	80	7-535585-3
	73.66[2.900]	76.20[3.000]	60	7-535585-2
	60.96[2.400]	63.50[2.500]	50	7-535585-1
	48.26[1.900]	50.80[2.000]	40	7-535585-0
	45.72[1.800]	48.26[1.900]	38	6-535585-9
	43.18[1.700]	45.72[1.800]	36	6-535585-8
	40.64[1.600]	43.18[1.700]	34	6-535585-7
	38.10[1.500]	40.64[1.600]	32	6-535585-6
	35.56[1.400]	38.10[1.500]	30	6-535585-5
	33.02[1.300]	35.56[1.400]	28	6-535585-4
	30.48[1.200]	33.02[1.300]	26	6-535585-3
	27.94[1.100]	30.48[1.200]	24	6-535585-2
	25.40[1.000]	27.94[1.100]	22	6-535585-1
	22.86[.900]	25.40[1.000]	20	6-535585-0
	20.32[.800]	22.86[.900]	18	5-535585-9
	17.78[.700]	20.32[.800]	16	5-535585-8
	15.24[.600]	17.78[.700]	14	5-535585-7
	7.62[.300]	10.16[.400]	8	5-535585-6
	5.08[.200]	7.62[.300]	6	5-535585-5
	2.54[.100]	5.08[.200]	4	5-535585-4
	-	2.54[.100]	2	5-535585-3
	12.70[.500]	15.24[.600]	12	5-535585-2
	10.16[.400]	12.70[.500]	10	5-535585-1

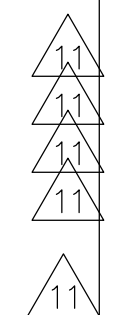

FINISH	B	A	NO OF POSN	PART NUMBER
--------	---	---	------------	-------------

THIS DRAWING IS A CONTROLLED DOCUMENT.

DIMENSIONS: mm [INCHES]	TOLERANCES UNLESS OTHERWISE SPECIFIED:	DRN: M. BINNER 06NOV2002	CHK: J. JOLSON 06NOV02	APPO: J. JOLSON 06NOV02	NAME: J. JOLSON	RECEPTACLE ASSEMBLY, MOD IV, DOUBLE ROW, DUAL ENTRY, .100X.100CL, VERTICAL MOUNT, AMPMODU
0. PLC ± .01	1. PLC ± .01	2. PLC ± .01	3. PLC ± .01	4. PLC ± .01	ANGLES ± .01	SIZE: A1
MATERIAL: 1	FINISH: 2, 9	WEIGHT: -	CAGE CODE: 114-25018	DRAWING NO: 108-25022	DATE: 05AUG08	REV: 1

CUSTOMER DRAWING SCALE 1:1 SHEET 1 OF 1 REV S1